

SP1905

Specifications

Fitting Position	FRT
Inner Width(mm)	132.60
Inner Height(mm)	59.90
Inner Thickness(mm)	17.00
Outer Width(mm)	132.60
Outer Height(mm)	59.90
Outer Thickness(mm)	17.00
Usage Number	D1912-9143, SDB2443, D11424MH, 13.0460-5645.2, P 30 107, EHT1912H, MGD1912CH, SP1905(SD) , 35183 , 1412.32
EAN	8809461755892
E-MARK	Approved

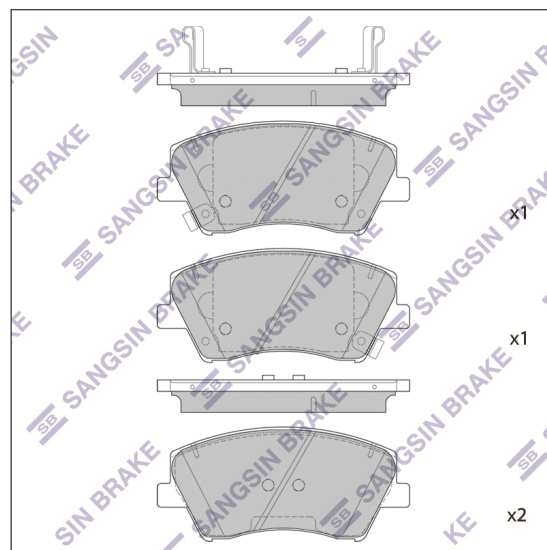

Application

HYUNDAI				
Model	Type	Kw	Year	
ELANTRA (AD)		2.0	01/16 -	

O.E References

Manufacturer	Reference
HYUNDAI	58101G2A00
HYUNDAI	58101F3A00
HYUNDAI	58101F0A00
HYUNDAI	58101F2A00
HYUNDAI	58101G2A10
KIA	58101G2A00